

1. Last week I taught in part 1Ti 6:1 where we reviewed slavery in antiquity and slavery in the New Testament and the importance of believers submitting to divinely vested authority. When time expired we were reviewing *The Doctrine of the Importance of Doctrine*.

2. Before returning to that study I want to give you opportunity to use 1Jo 1:9 as may be necessary.

3. So far we have exegeted that portion of the verse which in the KJV has been translated "Let as many servants as are under the yoke count their own masters worthy of all honor, that the name of God and his doctrine ..." noting it might better be rendered "**All who are slaves are under a yoke of bondage thus each must count his very own master worthy of all honor and respect in order that the noble and honorable name of God and His doctrine ...**"

4. The entire verse has been translated in the KJV:

1Ti 6:1 Let as many servants as are under the yoke count their own masters worthy of all honour, that the name of God and his doctrine be not blasphemed.

5. Now let's return to our study of Bible doctrine and its importance. I want to review some of that learned and then begin new material at point 14 on page four.

### **The Importance of Doctrine**

1. Definition: As used in this categorical study, doctrine is the content of Scripture exegeted and taught categorically by a pastor-teacher in a local church.

1.1 Col. R. B. Thieme developed an acrostic to communicate the way doctrine should be taught in the local church: ICE, for Isagogics, Categories and Exegesis. I have amplified it somewhat by adding a D for Dispensation..

2. In 2Ti 3:16-17 we find that doctrine is stressed as the means for performing the Christian life.

2Ti 3:16 All scripture is God breathed and is profitable for doctrine for reproof, for correction, for instruction in righteousness

2Ti 3:17 In order that the man of God might be perfect thoroughly furnished unto all good works.

2.1 Scripture, however, must be interpreted based on a complete and thorough exegesis.

3. 2Pe 1:2-9 summarizes the process for acquiring doctrine. In an earlier study of Peter's second epistle, I exegeted and analyzed verses two through eight. Rather than an extensive review, I want to simply present an expanded translation of 2Pe 1:2-9.

### Expanded Translation

**2Pe 1:2** God's wonderful plan for your life and the peace and stability that comes from that plan, I want it for each of you; however, you must realize it can only come from Bible doctrine metabolized in your soul, where the full knowledge of the Lord Jesus Christ becomes more real than reality.

**2Pe 1:3** For you see, God's divine power has provided everything that pertains to your life in time. Your spiritual life is a product of the doctrine you have in your soul. God called you for the solitary purpose of glorifying Him.

**2Pe 1:4** To facilitate our progress in the Christian life, God has provided in Scripture many great and precious promises; by the inculcation of these marvelous promises, you might become partakers of a divine nature, having escaped the control and domination of your old sin nature.

**2Pe 1:5** And because of God's grace, there are several protocols which must be added to your faith in Christ; for example, to your faith you must add the consistent intake of the Word of God and to this virtue you have to keep on adding more doctrine. The transforming of the mind is a never-ending task.

**2Pe 1:6** And to your newly acquired doctrine you must add self-control, organized thinking and patience as you continue metabolizing the Word of God, even when it is inconvenient, consistently making application of that which you have learned.

**2Pe 1:7** And to that application you must learn to appreciate your very own spiritual life, even while living right smack in the middle of the devil's world. And to this appreciation you must acquire a thorough understanding of God's protocols, some of which are very difficult and illogical. For example, you are to pray for your enemies; you are to do good to those who abuse you; you are to give thanks in all things and you are to pray regularly. You are to use your freedom in Christ as a liberty, not a license.

**2Pe 1:8** Now if the protocols listed in verses two through seven are resident in your soul, you will not be devoid of divine good; for these precious promises will make you a living testimony of Him who called you, as His ambassador for time.

**2Pe 1:9** But if anyone does not have them, he is nearsighted and blind, and has forgotten that he has been cleansed from his past sins.

4. The protocol plan of God is perhaps best summarized in our Ten Problem Solving Devices chart.

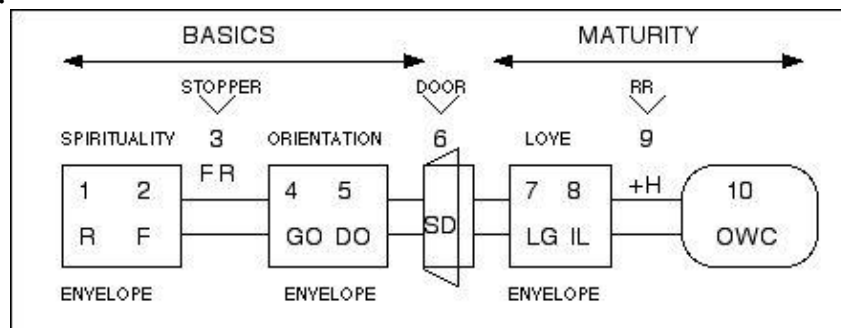

5. Now let's leave Second Peter and develop further our subject, *The Importance of Doctrine*.

6. It is impossible to please God if you do not believe that He is your Savior and that He blesses the believer who uses the two power options.

Heb 11:6 But without faith it is impossible to please him: for he that cometh to God must believe that he is, and that he is a rewarder of them that diligently seek him.

7. Without doctrine you will find your prayers to be an abomination to God.

Pro 28:9 He that turneth away his ear from hearing the law, even his prayers shall be an abomination.

8. Pro 12:1a tells us the man who loves spiritual growth will love knowledge.

Pro 12:1 Whoever loveth instruction loveth knowledge: and he that hateth reproof is brutish.

8.1 Notice Pro 12:1b tells us not to despise discipline; we should accept it and move forward. The man who rebels against the discipline of God is brutish--animal-like.

8.2 Compare this verse to Heb 4:12. The anonymous writer of Hebrews declares the power of Scripture, how it cuts to the essence of our soul and human spirit discerning our true thoughts and intents.

Heb 4:12 For the word of God is living and active. Sharper than any double-edged sword, it penetrates even to dividing soul and spirit, joints and marrow; it judges the thoughts and attitudes of the heart.

9. Doctrine was always with God, even from eternity past; before anything was, there was doctrine. Pro 8:22 and 23 also declare the importance God places on doctrine.

Pro 8:22-23 The Lord possessed wisdom in the beginning of his way, before his works of old. Wisdom was set up from everlasting, from the beginning, before the earth was.

10. God has magnified His Word, even above His name and reputation. A clear demonstration of the importance of His Word is found in Psa 138:2.

"I will worship toward the Holy Temple and praise thy Name for thy loving Kindness and for thy Truth: for thou hast magnified thy Word above all thy Name."

11. The attitude of a believer toward Bible doctrine determines whether he or she receives blessing or discipline in time. Pro 8:33-36

12. Jos 1:8 says daily study of the Word of God will make the believer a unique success.

Jos 1:8 This book of the law shall not depart out of your mouth; but thou shalt meditate therein day and night, that you may observe to do according to all that is written therein: for then you shall make thy way prosperous, and then you shall have a good success.

13. Doctrine, therefore, is the basis for blessing in time.

Psa 23:6 Surely goodness and mercy shall follow me all the days of my life: for I shall dwell in the house of the Lord forever.

14. Now for new material.

15. Doctrine must become more real than reality in the life of a believer.

KJV

2Pe 1:19 We have also a more sure word of prophecy; whereunto ye do well that ye take heed, as unto a light that shineth in a dark place, until the day dawn, and the day star arise in your heart

15.1 Let me give you an expanded translation of 2Pe 1:20 which demands a categorical study of Scripture.

### Expanded Translation

**2Pe 1:20 Know and understand no verse should be read and interpreted alone; i.e., it must not be isolated from what the Scripture says elsewhere.**

15.2 A chart might help illustrate 1Pe 1:20.

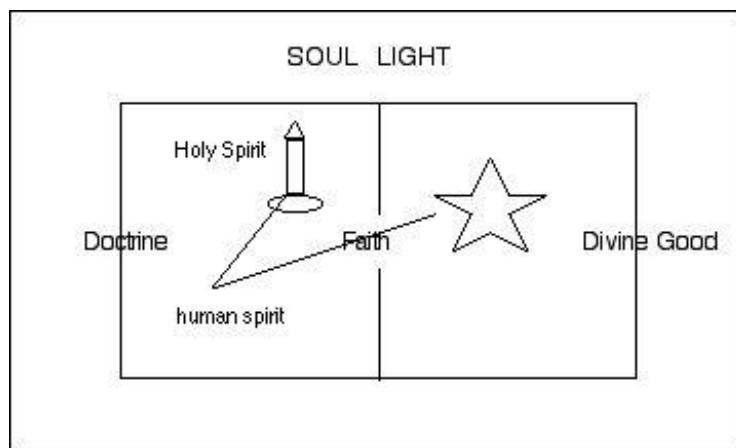

16. In order to function properly in time every believer is urged to get under the authority of his or her right pastor-teacher.

Heb 10:25 Not forsaking the assembling of ourselves together, as the manner of some is; but exhorting one another: and so much the more, as ye see the day approaching.

17. A nation without a pivot of positive believers will fall under the fifth cycle of discipline. As go the believers in a nation, so goes that nation.

Hos 4:1 Hear the word of the LORD, ye children of Israel: for the LORD hath a controversy with the inhabitants of the land, because there is no truth, nor mercy, nor knowledge of God in the land ...

Hos 4:6 My people are destroyed for lack of knowledge: because thou hast rejected knowledge, I will also reject thee, that thou shalt be no priest to me: seeing thou hast forgotten the law of thy God, I will also forget thy children.

18. The pastor-teacher in the local church has the responsibility for communicating doctrine.

Eph 4:11 And he gave some, apostles; and some, prophets; and some, evangelists; and some, *pastors-teachers*;

Eph 4:12 For the perfecting of the saints, for the work of the ministry, for the edifying of the body of Christ:

Eph 4:13 Till we all come in the unity of the faith, and of the knowledge of the Son of God, unto a perfect man, unto the measure of the stature of the fulness of Christ:

Eph 4:14 That we henceforth be no more children, tossed to and fro, and carried about with every wind of doctrine, by the sleight of men, and cunning craftiness, whereby they lie in wait to deceive;

19. Doctrine is only found in the written Canon.

1Pe 1:8 Whom having not seen, you love; in whom, though now you see him not, yet believing, you rejoice with joy unspeakable and full of glory:

Gal 1:8 But though we, or an angel from heaven, preach any other gospel unto you than that which we have preached unto you, let him be accursed.

End Lesson Taught 6-26-2017

**The Westbank Bible Church does not seek donations nor do we authorize any business to solicit same on behalf of the Church.**