

1. Last week I completed in part a study of 2Ti 3:16 and 17 and when the clock tolled 11:30 A.M. we were reviewing seven things that metabolized doctrine produces; all of this as a conclusion to our study of 2Ti 3:16-17.
2. Before we start the review, I want to give you opportunity to use 1Jo 1:9 as may or may not be necessary.
3. For a written and/or audio copy of this lesson please go to *westbankbiblechurch.com* and *click-on streaming audio of services*.
4. Seven things metabolized doctrine produces:

Confidence

Psa 118:8 It is better to trust in the LORD than to put confidence in man.

Psa 118:9 It is better to trust in the LORD than to put confidence in princes.

2Co 5:6 Therefore we are always confident, knowing that, while we are at home in the body, we are absent from the Lord:

2Co 5:7 (For we walk by faith, not by sight:)

2Co 5:8 We are confident, I say, and willing rather to be absent from the body, and to be present with the Lord.

Divine viewpoint

2Co 10:5 Casting down imaginations, and every high thing that exalt itself against the knowledge of God, and bringing into captivity every thought to the obedience of Christ;

Orientation to the plan of God

Rom 8:28 And we know that all things work together for good to them that love God, to them who are the called according to His purpose.

A stable mind

Isa 26:3 Thou wilt keep him in perfect peace, whose mind is stayed on thee: because he trusteth in thee.

2Ti 1:7 For God hath not given us the spirit of fear, but of power, and of love, and of a sound mind.

A basis for divine guidance

Rom 12:2 And be not conformed to this world but be ye transformed by the renewing of your mind, that you may know what is that good and acceptable and perfect will of God.

Rom 12:3 For I say, through the grace given unto me, to every man that is among you, not to think of himself more highly than he ought to think; but to think soberly, according as God hath dealt to every man the measure of faith.

All things that pertain to life and godliness

2Pe 1:2-3 Grace and peace be multiplied unto you through the knowledge of God, and of Jesus our Lord, according as his divine power hath given unto us all things which pertain unto life and godliness through the knowledge of him who has called us to glory and virtue.

Works acceptable to God--Metabolized Doctrine is the source of Christian production.

2Pe 1:3 According as his divine power hath given unto us all things that pertain unto life and godliness, through the knowledge of him that hath called us to glory and virtue:

2Pe 1:4 Whereby are given unto us exceeding great and precious promises: that by these ye might be partakers of the divine nature, having escaped the corruption that is in the world through lust.

2Ti 3:16 All scripture is given by inspiration of God, and is profitable for Doctrine, for reproof, for correction, for instruction in righteousness:

2Ti 3:17 That the man of God may be perfect, thoroughly furnished unto all good works.

Isa 55:11 So shall my word be that goeth forth out of my mouth: it shall not return unto me void, but it shall accomplish that which I please, and it shall prosper in the thing whereto I sent it.

Second Timothy Conclusions

1. To avail ourselves of Doctrine and thus avoid the catastrophe of being blinded by the lights of the world, we must consistently use our two power options; i.e., the intake of the Word and the filling of the Spirit.

2. This is the only way we can assemble the cast of characters listed by Peter in 2Pe 1:1-8.

2Pe 1:1 Simon Peter, a servant and an apostle of Jesus Christ, to them that have obtained like precious faith with us through the righteousness of God and our Saviour Jesus Christ:

2Pe 1:2 Grace and peace be multiplied unto you through the knowledge of God, and of Jesus our Lord,

2Pe 1:3 According as his divine power hath given unto us all things that pertain unto life and godliness, through the knowledge of him that hath called us to glory and virtue:

2Pe 1:4 Whereby are given unto us exceeding great and precious promises: that by these ye might be partakers of the divine nature, having escaped the corruption that is in the world through lust.

2Pe 1:5 And beside this, giving all diligence, add to your faith virtue; and to virtue knowledge;

2Pe 1:6 And to knowledge temperance; and to temperance patience; and to patience godliness;

2Pe 1:7 And to godliness brotherly kindness; and to brotherly kindness charity.

2Pe 1:8 For if these things be in you, and abound, they make you that ye shall neither be barren nor unfruitful in the knowledge of our Lord Jesus Christ.

3. For many Christians, their spiritual life is simply a one-act play. The first act for them is faith in Christ, but God desires that the show continue and the story line develop.

4. To avoid being a one-act play there must be a disciplined approach to rebound and study, rebound and study--the consistent use of the two power options.

5. Without the assembled characters the curtain will never rise on act two. A vast audience of unseen witnesses is waiting in the theater: the question perpetually remains.

6. Are you willing to claim the promises which lead to our very own spiritual destiny?

7. Now let's see what we can learn from 2Ti 4:1-2.

KJV

2Ti 4:1 I charge thee therefore before God, and the Lord Jesus Christ, who shall judge the quick and the dead at his appearing and his kingdom;

2Ti 4:2 Preach the word; be instant in season, out of season; reprove, rebuke, exhort with all longsuffering and doctrine.

NIV

2Ti 4:1 In the presence of God and of Christ Jesus, who will judge the living and the dead, and in view of his appearing and his kingdom, I give you this charge:

2Ti 4:2 Preach the Word; be prepared in season and out of season; correct, rebuke and encourage -- with great patience and careful instruction.

8. I think the best way to study these verses is to review the *Doctrine of the Problem Solving Devices*.

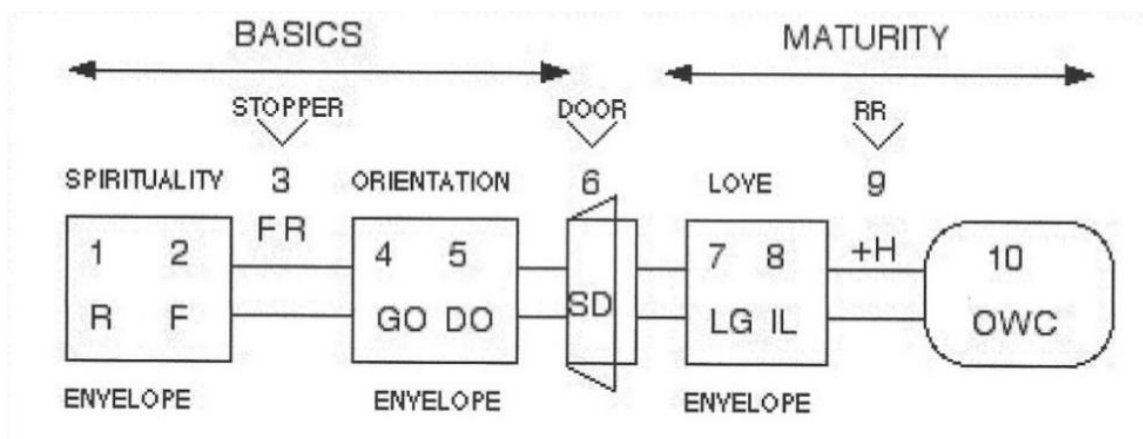

Problem-Solving Device Number One

Rebound is the divine mandate to maintain the filling of the Spirit and is the foundation for all other problem-solving devices. When you sin, confessing your sin to God is the only solution that allows you to restore your fellowship with God, and recover the filling of the Holy Spirit.

Psa 32:5 Then I acknowledged my sin to you and did not cover up my iniquity. I said, "I will confess my transgressions to the LORD" -- and you forgave the guilt of my sin.

Pro 28:13 He who conceals his sins does not prosper, but whoever confesses and renounces them finds mercy.

If you confess [name, cite, admit, acknowledge] your sins, He is faithful and righteous to forgive your sins [and to purify you from all unrighteousness].

1Jo 1:9 If we confess our sins, he is faithful and just and will forgive us our sins and purify us from all unrighteousness.

By using 1Jo 1:9 you will receive God's forgiveness absolutely and thus let you continue your spiritual growth by means of cycling the Word of God under the filling of the Spirit.

NIV

Rom 12:2 Do not conform any longer to the pattern of this world, but be transformed by the renewing of your mind. Then you will be able to test and approve what God's will is -- his good, pleasing and perfect will.

Rebound is not *victory* over sin and carnality; rebound is *recovery* from sin and carnality. Victory over sin is achieved only by learning and obeying the Word of God.

Problem-Solving Device Number Two

The filling of the Holy Spirit is a ministry of the Holy Spirit. This is the divine provision of power mandated by God for you to execute the Christian way of life.

Eph 5:18 Stop being intoxicated with wine, which is dissipation but be filled with the Spirit. The Holy Spirit reproduces the virtues of Christ in you as you use the ten problem solving devices. The Holy Spirit provides the power of God as the only means for learning Bible doctrine.

Joh 14:26 But the Comforter, which is the Spirit, whom the Father will send in my name, he shall teach you all things, and bring all things to your remembrance, whatsoever I have said unto you.

Thus, the filling of the Holy Spirit provides you with the ability to perceive and apply the infallible Word of God. With this power to obey God's mandates, the believer receives capacity for blessing and testing. However, the filling of the Holy Spirit alone is not the entire thrust of the Christian way of life.

After you have confessed your sins and are filled with the Spirit, you must, by your own decisions, continue to transform your mind and "walk by means of the Spirit" and utilize the other problem-solving devices.

KJV

Rom 12:2 Be you not conformed to this world but be you transformed by the renewing of the mind in order that you might know what is the good acceptable and perfect will of God.

Gal 5:16 This I say then, walk in the Spirit, and ye shall not fulfil the lust of the flesh.

Eph 2:10 For we are his workmanship, created in Christ Jesus unto good works, which God hath before ordained that we should walk in them.

Problem-Solving Device Number Three

Faith-rest is the technique that you apply to overcome any difficulty, problem, or disaster in your life. You first establish a relaxed mental attitude through rebound and the filling of the Holy Spirit.

Then by claiming a biblical promise, you concentrate on pertinent doctrines designed to restore your divine viewpoint. Faith-rest stabilizes your ability to think objectively under pressure.

Everyone is susceptible to fear, even the mature believer. When fear catches you off guard, you must quickly recover your mental poise, your ability to think and apply doctrine.

Isa 41:10 Fear thou not; for I am with thee: be not dismayed; for I am thy God: I will strengthen thee; yea, I will help thee; yea, I will uphold thee with the right hand of my righteousness.

God provides a step-by-step faith-rest technique for you to overcome fear and to recover your mental stability rapidly. First, you claim a biblical promise to stabilize your soul. There are many such promises found in Scripture.

As family of God you should glean a relevant doctrine applicable to your situation. God provided these divine solutions for you. He chose you to be part of His divine plan, so He can bless you in time and reward you in eternity. Let's look at several of the many faith-rest promises:

Phi 4:19 But my God shall supply all your needs according to his riches in glory by Christ Jesus.

Psa 56:11 In God have I put my trust: I will not be afraid what man can do unto me.

1Pe 5:6 Humble yourselves therefore under the mighty hand of God, that he may exalt you in due time:

1Pe 5:7 Casting all your care upon him; for he careth for you.

Jer 33:3 Call unto me, and I will answer thee, and shew thee great and mighty things, which thou knowest not.

Isa 41:10 Fear thou not; for I am with thee: be not dismayed; for I am thy God: I will strengthen thee; yea, I will help thee; yea, I will uphold thee with the right hand of my righteousness.

Deu 31:6 Be strong and of a good courage, fear not, nor be afraid of them: for the LORD thy God, he it is that doth go with thee; he will not fail thee, nor forsake thee.

2Ti 1:7 For God hath not given us the spirit of fear; but of power, and of love, and of a sound mind.

Also, remember that, even though a problem or situation may take you by surprise, omniscient God knew about that problem or situation in eternity past, and provided the perfect solution for it. After claiming any one of the many promises, you then can reach doctrinal conclusions.

Rom 8:31 What shall we then say to these things? [What conclusions are we forced to make?] If God be for us, who can be against us?

This is one of the most magnificent promises in the entire Bible. This promise confirms your eternal relationship with God, and His provision for you.

Problem-Solving Device Number Four

Grace orientation is the knowledge that the grace of God is His unmerited favor, extended to sinful humanity. Grace includes all that God is free to do for undeserving mankind, on the basis of the saving work of Jesus Christ on the Cross.

Isa 30:18 And therefore will the LORD wait, that he may be gracious unto you, and therefore will he be exalted, that he may have mercy upon you: for the LORD is a God of judgment: blessed are all they that wait for him.

God does all the work. You can only appropriate what He has already done. As a system of thinking, humility is free of arrogance and human viewpoint. Be clothed with humility: for God resists the proud, and gives grace to the humble. You realize that only the ability and power of God can meet your needs and provide answers and solutions to the problems of life.

A basic Christian virtue is respect for authority. Humility is an excellent synonym for grace orientation. Grace orientation leads to respect for authority, which in turn leads to “teachability.” As a Spirit filled believer humility allows you to assess your own strengths and weaknesses accurately.

With genuine humility, you will have the self-discipline necessary to submit to the plan of God and to obey God’s protocol.

Rom 12:3 For I say, through the grace given unto me, to every man that is among you, not to think of himself more highly than he ought to think [in terms of arrogance]; but to think soberly [in humility], according as God hath dealt to every man the measure of faith [a standard of thinking from doctrine.]

Problem-Solving Device Number Five

Doctrinal orientation is the perception and application of Bible doctrine that opens up the richest treasure in the universe--Doctrine.

The Bible is designated as the Word of God, and Bible doctrine is the thinking of God.

Heb 4:12 For the word of God is quick [alive], and powerful, and sharper than any two-edged sword, piercing even to the dividing asunder of soul and spirit and of the joints and marrow, and is a discerner [critic] of the thoughts and intents of the heart [mind].

Bible doctrine is the mind of Christ and you are exhorted to metabolize the mind of Christ, and grow in grace.

1Co 2:16 For who hath known the mind of the Lord, that He may instruct him? But we have the mind of Christ.

1Pe 4:1 Forasmuch then as Christ hath suffered for us in the flesh, arm yourselves likewise with the same mind: for he that hath suffered in the flesh hath ceased from sin;

1Pe 4:2 That he no longer should live the rest of his time in the flesh to the lusts of men, but to the will of God.

Phi 2:5 Let this mind be in you, which was also in Christ Jesus:

God's truth is your door to the reality of God and His marvelous plan. His Word is more reliable than anything you see, hear, smell, taste or feel-- more real than empirical knowledge.

2Pe 1:17 For he received from God the Father honor and glory, when there came such a voice to him from the excellent glory, This is my beloved Son, in whom I am well pleased.

2Pe 1:18 And this voice which came from heaven we heard, when we were with him in the holy mount.

2Pe 1:19 We have also a more sure word of prophecy; whereunto ye do well that ye take heed, as unto a light that shineth in a dark place, until the day dawn, and the day star arise in your hearts:

Learning Bible doctrine is the glue that holds all the problem-solving devices together.

Rom 12:3 For through the grace [orientation] given to me, I say to every man among you not to think more highly of himself [humility] than he ought to think, but to think so as to have sound judgment [divine viewpoint] as God has allotted to each [believer] a measure of faith [standard of thinking from doctrine].

Problem-Solving Device Number Six

A personal sense of destiny is developed when you begin to live your life in the light of eternity.

As the door to the entrance into the more advanced problem-solving devices, your self-worth becomes inseparably united with Jesus Christ because you share eternally all that Christ has and is:

His righteousness

2Co 5:21 For he hath made him to be sin for us, who knew no sin; that we might be made the righteousness of God in him.

His election

Eph 1:3 Blessed be the God and Father of our Lord Jesus Christ, who hath blessed us with all spiritual blessings in heavenly places in Christ:

Eph 1:4 According as he hath chosen us in him before the foundation of the world, that we should be holy and without blame before him in love:

His sonship

Gal 3:26 For ye are all the children of God by faith in Christ Jesus.

His priesthood

1Pe 2:5 Ye also, as lively stones, are built up a spiritual house, an holy priesthood, to offer up spiritual sacrifices, acceptable to God by Jesus Christ.

His kingship

Rev 20:6 Blessed and holy is he that hath part in the first resurrection: on such the second death hath no power, but they shall be priests of God and of Christ, and shall reign with him *forever*.

Your personal sense of destiny weathers all the storms of adversity, and further develops humility so that you understand God is the Source of all prosperity.

Rom 14:8 For whether we live, we live unto the Lord; and whether we die, we die unto the Lord: whether we live therefore, or die, we are the Lord's.

Problem-Solving Device Number Seven

Personal love for God is the virtue love that you gain from the perception and application of Bible doctrine.

God is the paragon for virtue love. Every believer, in both the Old Testament and New Testament, is commanded to love God.

Deu 6:5 And thou shalt love the LORD thy God with all thine heart, and with all thy soul, and with all thy might.

1Pe 1:8 Whom having not seen, ye love; in whom, though now ye see him not, yet believing, ye rejoice with joy unspeakable and full of glory:

To understand love of God, you must go to the source, which is God's love for you.

1Jo 4:19 We love Him because He first loved us.

The absolute standard of virtue love is God's divine essence, not relative systems of human ethics. God is perfect; therefore, His love is perfect. Divine love is far superior to the strongest human love you will ever know. Along with your love for God comes the confidence to face even the most extreme tests in life. As your love for God increases you gain absolute confidence that He directs even your problems for your benefit.

Love of God is commanded in Scripture.

Mat 22:37 Jesus said unto him, Thou shalt love the Lord thy God with all thy heart, and with all thy soul, and with all thy mind.

In the Kingdom Age the negative people who did not accept the Messiah's offering were said to not love God.

Joh 5:41 I receive not honor from men.

Joh 5:42 But I know you, that ye have not the love of God in you.

Joh 5:43 I am come in my Father's name, and ye receive me not: if another shall come in his own name, him ye will receive.

Problem-Solving Device Number Eight

Impersonal love for all mankind is the unconditional love you have toward others, which reflects your personal love for God. You respect the privacy and freedom of others, and learn to “live and let live.”

Rom 14:4 Who art thou that judgest another man's servant? to his own master he standeth or falleth. Yea, he shall be holden up: for God is able to make him stand.

This means you abstain from gossip, maligning, judging, character assassination, and evil speculations from rumors and hearsay.

Mat 7:1 Judge not, that ye be not judged.

Mat 7:2 For with what judgment ye judge, ye shall be judged: and with what measure ye mete, it shall be measured to you again.

Mat 7:3 And why beholdest thou the mote that is in thy brother's eye, but considerest not the beam that is in thine own eye?

Mat 7:4 Or how wilt thou say to thy brother, Let me pull out the mote out of thine eye; and, behold, a beam is in thine own eye?

Mat 7:5 Thou hypocrite, first cast out the beam out of thine own eye; and then shalt thou see clearly to cast out the mote out of thy brother's eye.

People comprise some of the most severe tests in life. Some of your associations may be obnoxious or evil. Even for loved ones or close companions, a constant personal love is difficult to maintain. How, then, can you obey the biblical command to “love your neighbor as yourself?”

Mat 19:19 Honour thy father and thy mother: and, thou shalt love thy neighbour as thyself.

When you are occupied with Christ, you will love all people using impersonal love thus loving your neighbor as yourself.

Rom 13:8 Owe nothing to anyone except to love one another; for he who loves his neighbor has fulfilled the law.

Unconditional love flows from your integrity rather than from the attractiveness of the object. This is the same unconditional love God bestowed on the entire human race when He “so loved the world, that He gave His only begotten Son, that whoever believes in Him should not perish, but have eternal life” (Joh 3:16). God planned and implemented the salvation of unbelievers.

Your impersonal love derived from your virtue love for God, takes precedence over the faults and flaws of people. When personal love for God and impersonal unconditional love for all mankind unite, they form virtue love. Virtue love is not encumbered by cruel intolerance, smoldering anger, judging, hatred, or other mental attitude sins. You are not distracted by stress, pressure problems, or persecutions. You obey and imitate the Lord by repaying insults and antagonism with compassion, kindness, patience, and humility.

1Co 13:4 Love is patient, love is kind, *and* is not jealous; love does not brag *and* is not arrogant,

1Co 13:5 does not act unbecomingly; it does not seek its own, is not provoked, does not take into account a wrong *suffered*,

1Co 13:6 does not rejoice in unrighteousness, but rejoices with the truth;

1Co 13:7 bears all things, believes all things, hopes all things, endures all things.

Problem-Solving Device Number Nine

Sharing the happiness of God is God’s ultimate goal for your life. Your sharing God’s happiness is the culmination and intensification of all the other problem-solving devices.

Joh 15:9 As the Father hath loved me, so have I loved you: continue ye in my love.

Joh 15:10 If ye keep my commandments, ye shall abide in my love; even as I have kept my Father's commandments, and abide in his love.

Joh 15:11 These things have I spoken unto you, that my joy might remain in you, and that your joy might be full.

The pattern for this wonderful happiness began with Jesus Christ during His excruciating crucifixion. His relaxed mental attitude equated adversity with prosperity, and dying with living. He never felt threatened or sorry for Himself; His happiness did not change even under dreadful circumstances, cruelty, torture, unjust treatment, or death. You have access to the same happiness in your life.

Phi 4:11 Not that I speak in respect of want: for I have learned, in whatsoever state I am, therewith to be content.

Phi 4:12 I know both how to be abased, and I know how to abound: everywhere and in all things I am instructed both to be full and to be hungry, both to abound and to suffer need.

Phi 4:13 I can do all things through Christ which strengtheneth me.

Problem-Solving Device Number Ten

Occupation with Christ is the pinnacle or penthouse of the Christian way of life, it is when you love and respect Jesus Christ, His person and work intensely.

By using the nine problem-solving devices, you develop a concentrated focus on Jesus Christ; it is here your attention becomes riveted on Him. Despite the pressure and suffering that surrounds you, you can be stabilized by your constant awareness of the Lord.

When you are occupied with Christ, He is your role model, the pattern for your life, your closest companion Who influences your thoughts.

Rom 14:7 For none of us liveth to himself, and no man dieth to himself.

Rom 14:8 For whether we live, we live unto the Lord; and whether we die, we die unto the Lord: whether we live therefore, or die, we are the Lord's.

Rom 14:9 For to this end Christ both died, and rose, and revived, that he might be Lord both of the dead and living.

When your capacity for personal love for God has reached the point of occupation with Christ, God can entrust you with phenomenal blessings and testing. Since your spiritual life depends upon encouragement only from Christ, you cease to depend upon people for love, happiness, help, or support.

You have become spiritually self-sustaining. No problem, suffering, no disaster, shock or pressure can intrude on your soul and dim the illuminating presence of the Lord Jesus Christ.

Phi 1:20 According to my earnest expectation and my hope [absolute confidence], that I shall not be put to shame [discouragement] in anything [testing or suffering], but that with all boldness [courage], Christ shall even now, as always, be exalted in my body, whether by life, or by death.

Phi 1:21 For to me, to live is Christ, and to die is gain [profit or benefit].