

Doctrine of the Problem Solving Devices

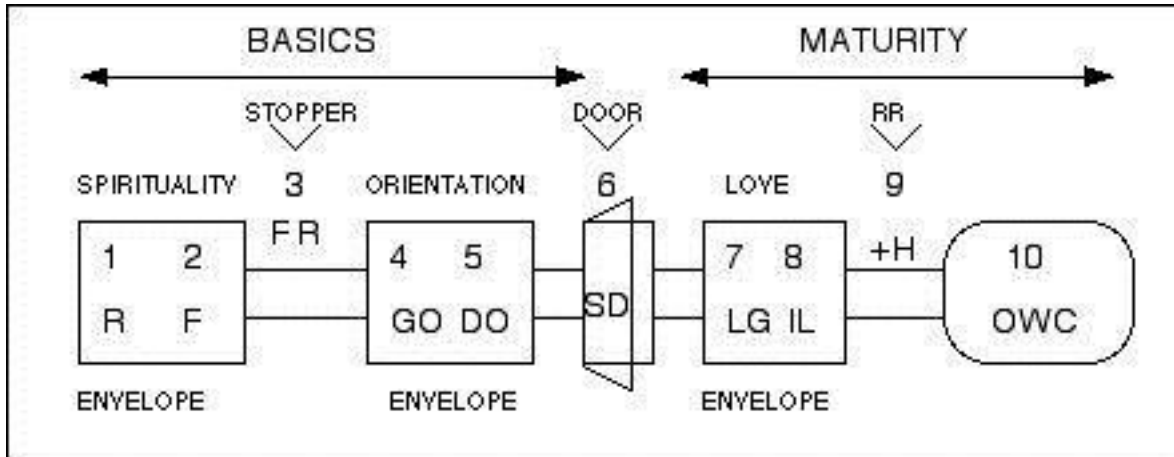

1. Spirituality Envelope

1.1 Rebound and the Filling of the Spirit

Rebound must be understood in the light of positional truth. Faith alone in Christ alone provides us positional sanctification; we can never lose our positional sanctification.

Acts 16:31 They replied, "Believe in the Lord Jesus, and you will be saved--you and your household."

Eph 2:8-9 For by grace you have been saved through faith and not from yourselves, it is the gift of God -- not by works, so that no one can boast.

Rebound means a recovery of fellowship because you cite the sin shown to you by God the Holy Spirit, thus you regain the filling of the Holy Spirit.

An understanding of eternal security is a requisite for understanding rebound. Rebound recovers the filling, you can never lose the indwelling.

Rom 8:38 For I am convinced that neither death nor life, neither angels nor demons, neither the present nor the future, nor any powers,

Rom 8:39 neither height nor depth, nor anything else in all creation, will be able to separate us from the love of God that is in Christ Jesus our Lord.

1.2 Mechanics of Rebound

Name the sin

1Jo 1:9 If we confess our sins, he is faithful and just and will forgive us our sins and purify us from all unrighteousness.

Forget the sin

Phi 3:13 Brothers, I do not consider myself yet to have taken hold of it. But one thing I do: Forgetting what is behind and straining toward what is ahead,
Phi 3:14 I press on toward the goal to win the prize for which God has called me heavenward in Christ Jesus.

Isolate the sin

Psa 32:5 Then I acknowledged my sin to you and did not cover up my iniquity. I said, "I will confess my transgressions to the LORD"--and you forgave the guilt of my sin.

The alternative to rebound--discipline--prayers not heard

1Co 11:31 But if we judged ourselves, we would not come under judgment.
1Co 11:32 When we are judged by the Lord, we are being disciplined so that we will not be condemned with the world.

Psa 66:18 If I had cherished sin in my heart, the Lord would not have listened;

2. The Stopper--Faith Rest

2.1 We faith rest when we trust God to take care of us.

Helpful Scriptures

Psa 118:8 It is better to trust in the LORD than to put confidence in man.
Psa 118:9 It is better to trust in the LORD than to put confidence in princes.
Psa 118:10 All nations compassed me about: but in the name of the LORD will I destroy them.

Pro 3:26 For the LORD shall be your confidence, and shall keep your foot from being snared.

Pro 14:26 In the fear and respect of the LORD is strong confidence: and his children shall have a place of refuge.

Rom 8:31 What shall we then say to these things? If God be for us, who can be against us?

Rom 8:32 He that spared not his own Son, but delivered him up for us all, how shall he not with him also freely give us all things?

Rom 8:38 For I am persuaded, that neither death, nor life, nor angels, nor principalities, nor powers, nor things present, nor things to come,

Rom 8:39 Nor height, nor depth, nor any other creature, shall be able to separate us from the love of God, which is in Christ Jesus our Lord.

Isa 30:20 And though the Lord give you the bread of adversity, and the water of affliction, yet shall not thy teachers be removed into a corner any more, but thine eyes shall see thy teachers:

Isa 30:21 And thine ears shall hear a word behind thee, saying, This is the way, walk ye in it, when ye turn to the right hand, and when ye turn to the left.

Deu 31:6 Be strong and of a good courage, fear not, nor be afraid of them: for the LORD thy God, he it is that doth go with thee; he will not fail thee, nor forsake thee.

Deu 31:7 And Moses called unto Joshua, and said unto him in the sight of all Israel, Be strong and of a good courage: for thou must go with this people unto the land which the LORD hath sworn unto their fathers to give them; and thou shalt cause them to inherit it.

Deu 31:8 And the LORD, he it is that doth go before thee; he will be with thee, he will not fail thee, neither forsake thee: fear not, neither be dismayed.

Isa 41:10 Fear thou not; for I am with thee: be not dismayed; for I am thy God: I will strengthen thee; yea, I will help thee; yea, I will uphold thee with the right hand of my righteousness.

Isa 41:11 Behold, all they that were incensed against thee shall be ashamed and confounded: they shall be as nothing; and they that strive with thee shall perish.

Isa 41:12 Thou shalt seek them, and shalt not find them, even them that contended with thee: they that war against thee shall be as nothing, and as a thing of nought.

Isa 41:13 For I the LORD thy God will hold thy right hand, saying unto thee, Fear not; I will help thee.

2Ti 1:7 For God hath not given us the spirit of fear; but of power, and of love, and of a sound mind.

Psa 56:3 What time I am afraid, I will trust in thee.

Psa 23:4 Yea, though I walk through the valley of the shadow of death, I will fear no evil: for thou art with me; thy rod and thy staff they comfort me.

Phi 4:6 Be careful for nothing; but in every thing by prayer and supplication with thanksgiving let your requests be made known unto God.

Phi 4:7 And the peace of God, which passeth all understanding, shall keep your hearts and minds through Christ Jesus.

1Sa 17:47 And all this assembly shall know that the LORD saveth not with sword and spear: for the battle is the LORD'S, and he will give them into our hands.

Isa 26:3 Thou wilt keep him in perfect peace, whose mind is stayed on thee: because he trusteth in thee.

Isa 26:4 Trust ye in the LORD for ever: for in the LORD JEHOVAH is everlasting strength:

Phi 4:19 But my God shall supply all your need according to his riches in glory by Christ Jesus.

Psa 56:4 In God I will praise his word, in God I have put my trust; I will not fear what flesh can do unto me.

Psa 4:8 I will lie down and sleep in peace, for you alone, O LORD, make me dwell in safety.

Jer 29:11 For I know the plans I have for you," declares the LORD, "plans to prosper you and not to harm you, plans to give you hope and a future.

Isa 51:12 "I, even I, am he who comforts you. Who are you that you fear mortal men, the sons of men, who are but grass,

Isa 51:13 that you forget the LORD your Maker, who stretched out the heavens and laid the foundations of the earth, that you live in constant terror every day because of the wrath of the oppressor, who is bent on destruction? For where is the wrath of the oppressor?

Isa 51:14 The covering prisoners will soon be set free; they will not die in their dungeon, nor will they lack bread.

Isa 51:15 For I am the LORD your God, who churns up the sea so that its waves roar-- the LORD Almighty is his name.

3. Orientation Envelope

3.1 Grace Orientation

Grace is all that God is free to do for us on the basis of the Cross without in any way compromising His perfect character.

God's perfect character remains intact because Christ was judged for all sin and we appropriate His forgiveness for sin when we believe on the Lord Jesus Christ and are saved.

Joh 3:17 For God sent not his Son into the world to condemn the world; but that the world through him might be saved.

Joh 3:18 He that believeth on him is not condemned: but he that believeth not is condemned already, because he hath not believed in the name of the only begotten Son of God.

Grace is not Withheld Because of Demerit. All questions of demerit have been banished. Thus God is righteously free to exercise grace in every case. Salvation is by grace alone.

Rom 4:1 What shall we say then that Abraham our father, as pertaining to the flesh, hath found?

Rom 4:2 For if Abraham were justified by works, he hath whereof to glory; but not before God.

Rom 4:3 For what saith the scripture? Abraham believed God, and it was counted unto him for righteousness.

Rom 4:4 Now to him that works the reward is not of grace, but of debt.

Rom 4:5 But to him that worketh not, but believeth on him that justifieth the ungodly, his faith is counted for righteousness.

Rom 4:6 Even as David also describeth the blessedness of the man, unto whom God imputeth righteousness without works,

Rom 4:7 Saying, Blessed are they whose iniquities are forgiven, and whose sins are covered.

Rom 4:8 Blessed is the man to whom the Lord will not impute sin.

Grace cannot be lessened because of demerit. God cannot in grace do more for one who is more sinful than for one who is less sinful. This because Christ on the cross has forever taken care of the sin problem.

1Jo 2:2 And he is the propitiation for our sins: and not for ours only, but also for the sins of the whole world.

1Pe 3:18 For Christ also hath once suffered for sins, the just for the unjust, that he might bring us to God, being put to death in the flesh, but made alive by the Spirit:

Grace cannot incur a debt.

Joh 10:28 "And I give unto them eternal life; and they shall never perish ...

Rom 6:23 ... the gift of God is eternal life through Jesus Christ our Lord.

Joh 3:16 "For God so loved the world, that he gave his only begotten Son, that whosoever believeth in him should not perish, but have everlasting life."

Grace is not exercised in the just Payment of a debt. For the sole purpose that pure grace might be exercised toward men, the human family has been placed under the divine judicial sentence of sin. It is obviously true that all men are sinners both by nature and by practice. For God has pronounced an equal and absolute sentence of judgment against all men. Mankind was condemned at birth and in need of a rebirth.

Rom 5:12 Wherefore, as by one man sin entered into the world, and death by sin; and so death passed upon all men, for that all have sinned:

Rom 5:13 (For until the law sin was in the world: but sin is not imputed when there is no law.

Rom 5:14 Nevertheless death reigned from Adam to Moses, even over them that had not sinned after the similitude of Adam's transgression ...

Eph 2:2 Wherein in time past ye walked according to the course of this world, according to the prince of the power of the air, the spirit that now worketh in the children of disobedience:

Rom 3:9 What then? are we better than they? No, in no wise: for we have before proved both Jews and Gentiles, that they are all under sin;

Rom 3:10 As it is written, There is none righteous, no, not one:

Gal 3:22 But the scripture hath concluded all under sin, that the promise by faith of Jesus Christ might be given to them that believe.

3.2 Doctrinal Orientation

Bible Doctrine must be more real than reality.

Rom 12:2 And be not conformed to this world: but be ye transformed by the renewing of your mind, that ye may prove what is that good, and acceptable, and perfect, will of God.

2Pe 1:3 According as his divine power hath given unto us all things that pertain unto life and godliness, through the knowledge of him that hath called us to glory and virtue:

2Pe 1:4 Whereby are given unto us exceeding great and precious promises: that by these ye might be partakers of the divine nature, having escaped the corruption that is in the world through lust.

4. The Door--Sense of Destiny

4.1 God has a plan for your life--to fulfill His will and purpose.

The believer resides in the eternal plan of God and shares the destiny of Christ.
We are foreknown, elected, predestined, chosen and called.

Rom 8:31 What shall we then say to these things? If God be for us, who can be against us?

Rom 8:32 He that spared not his own Son, but delivered him up for us all, how shall he not with him also freely give us all things?

1Pe 1:1 Peter, an apostle of Jesus Christ, To God's elect, strangers in the world, scattered throughout Pontus, Galatia, Cappadocia, Asia and Bithynia,

1Pe 1:2 who have been chosen according to the foreknowledge of God the Father, through the sanctifying work of the Spirit, for obedience to Jesus Christ and sprinkling by his blood: Grace and peace be yours in abundance.

Col 3:23 Whatever you do, work at it with all your heart, as working for the Lord, not for men,

Col 3:24 since you know that you will receive an inheritance from the Lord as a reward. It is the Lord Christ you are serving.

Eph 4:1 I therefore, the prisoner of the Lord, beseech you that ye walk worthy of the vocation wherewith ye are called ...

5. Love Envelope

5.1 Love of God

The love of God is commanded in Scripture.

Deu 6:5 And thou shalt love the LORD thy God with all thine heart, and with all thy soul, and with all thy might.

Deu 10:12 And now, Israel, what doth the LORD thy God require of thee, but to fear the LORD thy God, to walk in all his ways, and to love him, and to serve the LORD thy God with all thy heart and with all thy soul,

Mat 22:37 Jesus said unto him, Thou shalt love the Lord thy God with all thy heart, and with all thy soul, and with all thy mind.

Capacity for loving God comes from doctrine cycled in your soul.

1Jo 5:2 By this we know that we love the children of God, when we love God, and keep his commandments.

1Jo 5:3 For this is the love of God, that we keep his commandments: and his commandments are not grievous.

The love of God reaches its acme at "spiritual maturity" as evidenced in Paul's attitude while imprisoned.

Phi 1:20 I eagerly expect and hope that I will in no way be ashamed, but will have sufficient courage so that now as always Christ will be exalted in my body, whether by life or by death.

Phi 1:21 For to me, to live is Christ and to die is gain.

Phi 1:22 If I am to go on living in the body, this will mean fruitful labor for me. Yet what shall I choose? I do not know!

Phi 1:23 I am torn between the two: I desire to depart and be with Christ, which is better by far;

Phi 1:24 but it is more necessary for you that I remain in the body.

The same is made clear by John in his attitude. All of the loves in the next two verses are from agape.

1Jo 4:17 Herein is our love made perfect, that we may have boldness in the day of judgment: because as he is, so are we in this world.

1Jo 4:18 There is no fear in love; but perfect love casteth out fear: because fear hath torment. He that feareth is not made perfect in love.

As a believer you acquire a love when you cycle doctrine in your soul.

Expanded Translation:

Eph 3:18 In order that you may be able to comprehend together with other Christians in Bible class a full and complete understanding of Doctrine

Eph 3:19 and therefore know the love of God which superabounds by means of doctrine in your right lobes with the fullness of God.

5.2 Impersonal Love

Impersonal love is the right mental attitude demanded of Christians toward all people, even if they in your view have no redeeming qualities whatsoever. This type of love was best expressed by our Lord on the cross when He said of those who had used and abused Him:

Luk 23:34 Then said Jesus, Father, forgive them; for they know not what they do. And they parted his raiment, and cast lots.

Impersonal love is that attitude displayed because the Scripture commands a proper mental attitude toward others.

Mat 5:43 Ye have heard that it hath been said, Thou shalt love thy neighbor, and hate thine enemy.

Mat 5:44 But I say unto you, Love your enemies, bless them that curse you, do good to them that hate you, and pray for them which despitefully use you, and persecute you;

The same concept is taught in many of the epistles to the Church.

1Th 4:9 But as touching brotherly love ye need not that I write unto you: for ye yourselves are taught of God to love one another.

6. Rest and Recuperation--+H

6.1 Plus Happiness is sharing the happiness of God.

There is need in time just to relax and enjoy the life that God has given you. We indeed are commanded to share the happiness of God.

Joh 15:11 These things have I spoken unto you, that my happiness might remain in you, and that your joy and happiness might be full.

Joh 17:13 And now come I to you; and these things I speak in the world that they might have my joy fulfilled in themselves."

God promises special blessing and happiness to the person who is positive to the Word--to those who fear and respect the Lord.

Pro 16:20 He that handleth a matter wisely shall find good: and whoso trusteth in the LORD, happy is he.

Pro 16:21 The wise in heart shall be called prudent: and the sweetness of the lips increaseth learning.

Pro 16:22 Understanding is a wellspring of life unto him that hath it: but the instruction of fools is folly.

Pro 16:23 The heart of the wise teacheth his mouth, and addeth learning to his lips.

Pro 16:24 Pleasant words are as an honeycomb, sweet to the soul, and health to the bones.

Psa 128:1 Happy are all who fear the LORD, who walk in his ways.

Psa 128:2 You will eat the fruit of your labor; blessings and prosperity will be yours.

Psa 128:3 Your wife will be like a fruitful vine within your house; your sons will be like olive shoots around your table.

Psa 128:4 Thus is the man blessed who fears and respects the LORD.

7. Occupation With Christ

7.1 To be occupied with Christ is to let the mind of Christ control your life.

Being occupied with Christ is the ultimate reward for the believer.

2Co 13:11 Finally, brethren, farewell. Be perfect, be of good comfort, be of one mind, live in peace; and the God of love and peace shall be with you.

Phi 1:27 Only let your conversation be as it becometh the gospel of Christ: that whether I come and see you, or else be absent, I may hear of your affairs, that ye stand fast in one spirit, with one mind striving together for the faith of the gospel;

Phi 2:5 Let this mind be in you, which was also in Christ Jesus:

1Co 1:10 Now I beseech you, brethren, by the name of our Lord Jesus Christ, that ye all speak the same thing, and that there be no divisions among you; but that ye be perfectly joined together in the same mind and in the same judgment.

1Co 2:16 For who hath known the mind of the Lord, that he may instruct him? But we have the mind of Christ.

Phi 4:8 Finally, brethren, whatsoever things are true, whatsoever things are honest, whatsoever things are just, whatsoever things are pure, whatsoever things are lovely, whatsoever things are of good report; if there be any virtue, and if there be any praise, think on these things.